



Project: .....

Location: .....

Item #: .....

Quantity: .....

## Model: Coral – 14 & 18

Variant	Op Temp & Storage
CWM14S3	+1/+4 General Produce
CWM18S3	+1/+4 General Produce

### Key Features

- Wall mounted refrigerated counter accommodating a combination of racking
- Stainless steel exterior and stainless steel interior
- Self closing sliding glass door with stainless steel handles
- CoolSmart intelligent controller offering 15% energy savings, enhanced performance; energy efficient economy mode ensuring effective temperature control for excellent food safety and improved defrost functionality for increased cabinet efficiency
- CoolSmart controller is designed for easy operation and features clear digital display and visual alarm
- Environmentally friendly 75mm GWP low foam injected insulation for excellent thermal efficiency
- Designed for effective and efficient performance in 32°C ambient environments
- Facility to connect to a wide range of temperature monitoring and control systems including Williams TAB system
- HACCP compliant

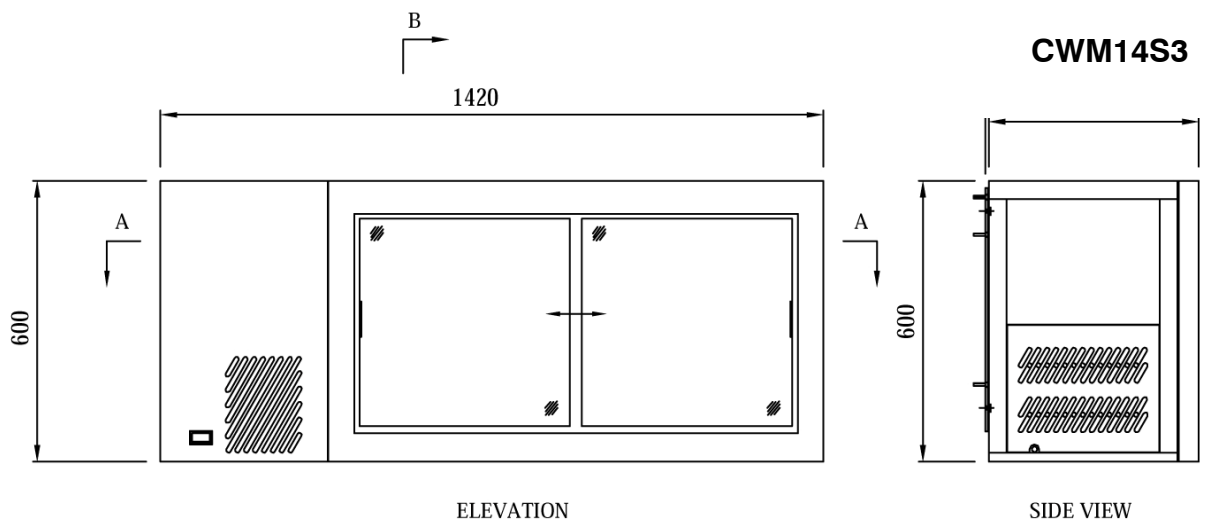



## Dimensions

	CWM14	CWM18
<b>External (mm):</b>	H600	H600
	W1420	W1885
<b>Depth - allow extra 15mm for handle</b>	D457	D457
<b>Internal (mm):</b>	H518	H518
<b>(width per compartment)</b>	W978	W1445
	D360	D360
<b>Sliding Door Opening Width (mm):</b>	W405	W630
<b>Packed:</b>	H	H
	W	W
	D	D
<b>Weight:</b>	88kg	110kg
<b>Add 5kg per product for packing</b>		



## Important Information

	CWM14	CWM18
<b>Capacity:</b> cu.ft/litres		
<b>Construction:</b> Exterior (SS)	0.7mm stainless steel	0.7mm stainless steel
Interior	0.7mm stainless steel	0.7mm stainless steel
Door		
<b>Power Supply:</b>	13amp plug top	13amp plug top
<b>Power Input:</b> Start Up	10.7 amps	10.7 amps
Running	2.5 amps	2.5 amps
Compressor HP	¼	¼
<b>Energy Consumption:</b>	4.32kW in 24hr	5.61kW in 24hr
<b>Heat Rejection:</b> (Evaporating at -10°C in 32°C ambient)	560 watts	560 watts
<b>Refrigerant::</b>	R134a	R134a
<b>Defrost:</b>	Automatic off-cycle	Automatic off cycle
<b>Insulation:</b> GWP low foam	75mm	75mm
<b>Noise Output:</b>	59 dBA ?	59 dBA ?

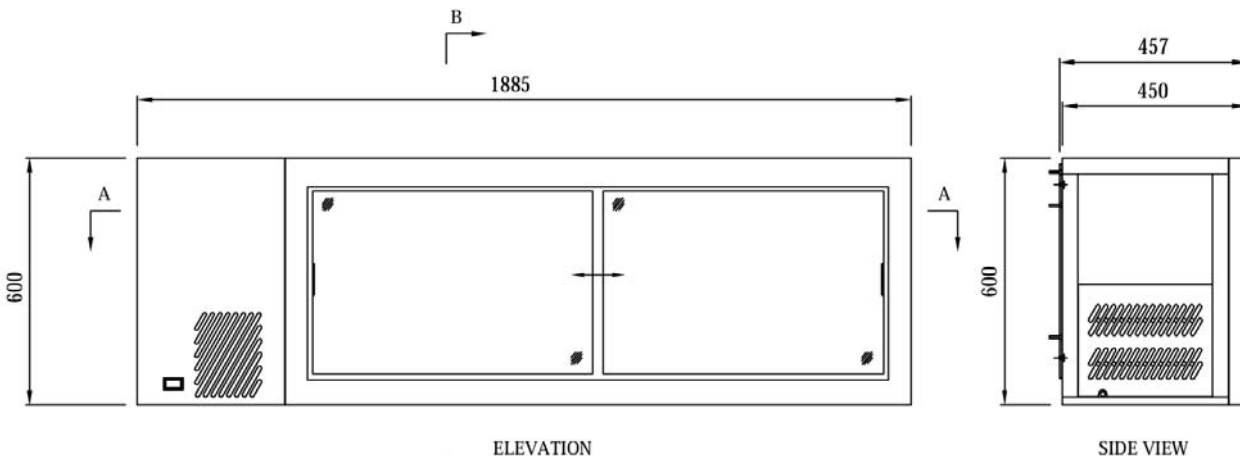

Williams are committed to a policy continuing product development and innovation and as such, we reserve the right to change product specifications stated without prior notice.

**All refrigeration equipment requires adequate ventilation for efficient and effective performance.**



Williams Refrigeration  
 Bryggen Road, North Lynn Industrial Estate King's Lynn, PE30 2HZ.  
 Tel: +44 (0)1553 817 000 Fax: +44 (0)1553 817 111 Spares: +44 (0)1553 817017  
 Website: [www.williams-refrigeration.com](http://www.williams-refrigeration.com) e.mail: [info@williams-refrigeration.co.uk](mailto:info@williams-refrigeration.co.uk)



V2 - 0208-LG